



WPC Qi-compliant Wireless Power Series

NFC-compatible Wireless Power Transmitter for Automotive Applications BD57121MUF-M Evaluation Board

BD57121MUF-EVK-001

User's Guide

<High Voltage Safety Precautions>

◇ Read all safety precautions before use

Please note that this document covers only the BD57121MUF-M evaluation board (BD57121MUF-EVK-001) and its functions. For additional information, please refer to the datasheet.

To ensure safe operation, please carefully read all precautions before handling the evaluation board



Depending on the configuration of the board and voltages used,

Potentially lethal voltages may be generated.

Therefore, please make sure to read and observe all safety precautions described in the red box below.

Before Use

- [1] Verify that the parts/components are not damaged or missing (i.e. due to the drops).
- [2] Check that there are no conductive foreign objects on the board.
- [3] Be careful when performing soldering on the module and/or evaluation board to ensure that solder splash does not occur.
- [4] Check that there is no condensation or water droplets on the circuit board.

During Use

- [5] Be careful to not allow conductive objects to come into contact with the board.
- [6] **Brief accidental contact or even bringing your hand close to the board may result in discharge and lead to severe injury or death.**

Therefore, DO NOT touch the board with your bare hands or bring them too close to the board.

In addition, as mentioned above please exercise extreme caution when using conductive tools such as tweezers and screwdrivers.

- [7] If used under conditions beyond its rated voltage, it may cause defects such as short-circuit or, depending on the circumstances, explosion or other permanent damages.
- [8] Be sure to wear insulated gloves when handling is required during operation.

After Use

- [9] The ROHM Evaluation Board contains the circuits which store the high voltage. Since it stores the charges even after the connected power circuits are cut, please discharge the electricity after using it, and please deal with it after confirming such electric discharge.
- [10] Protect against electric shocks by wearing insulated gloves when handling.

This evaluation board is intended for use only in research and development facilities and should be handled **only by qualified personnel familiar with all safety and operating procedures.**

We recommend carrying out operation in a safe environment that includes the use of high voltage signage at all entrances, safety interlocks, and protective glasses.

WPC Qi-compliant Wireless Power Series

NFC-compatible Wireless Power Transmitter for Automotive Applications BD57121MUF-M Evaluation Board

BD57121MUF-EVK-001

BD57121MUF-EVK-001 Evaluation Board is based on the BD57121MUF-M Automotive-grade wireless power transmitter IC. This board integrates the ST25R3914 NFC reader/writer IC from ST Microelectronics to detect the presence of any NFC cards or tags and to prevent damaging of the NFC antennae by the wireless power transfer system. Wireless power transfer is compliant with WPC Qi ver1.2.4 and can supply power up to 15 W (output in receiver). Detection and identification of NFC Type A, B, F and V are possible.

Features

- Compliance to WPC Qi ver1.2.4
- Support of Multiple coils to increase charging area (Qi MP-A13 coil type)
- Power control using fixed frequency and variable voltage
- NFC card / tag detection of Type A, B, F, V
- Housing size: 120 mm x 65 mm x 30 mm

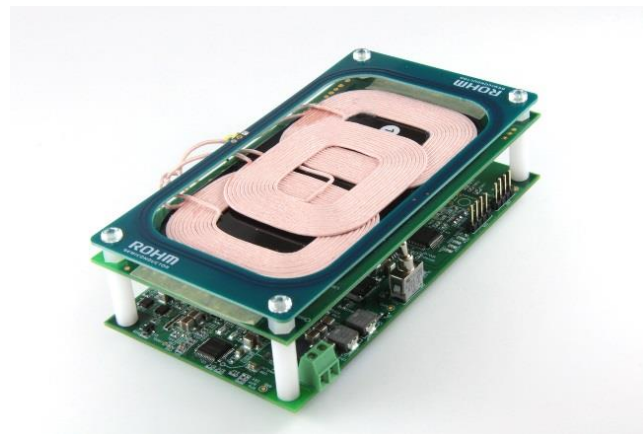

Figure 1. BD57121MUF-EVK-001 Evaluation Board

Performance specification

These are only representative values, and they do not represent guaranteed values of the product characteristics.

V_{IN} = 12 V, unless otherwise specified.

Parameter	Min	Typ	Max	Units	Conditions
Input voltage	11.0	12.0	13.0	V	
Output voltage (receiver side)	-	12.0	-	V	Using BD57015GWL-EVK-002 Rx board
Output current (receiver side)	0	-	1.25	A	Using BD57015GWL-EVK-002 Rx board
Dark current	-	0	5	μA	SW1=OFF
Operating frequency (Wireless power)	-	127.8	-	kHz	

Evaluation Board

1. System configuration for wireless power transfer and NFC

Wireless power transfer system consists of a two-way power transmission and communication system using a transmitter and a receiver, and the NFC system also communicates between the reader (= transmitter) and the listener. A single Microcontroller (MCU) controls both wireless power transmission and NFC reader, so it is possible to have seamless operation between each other.

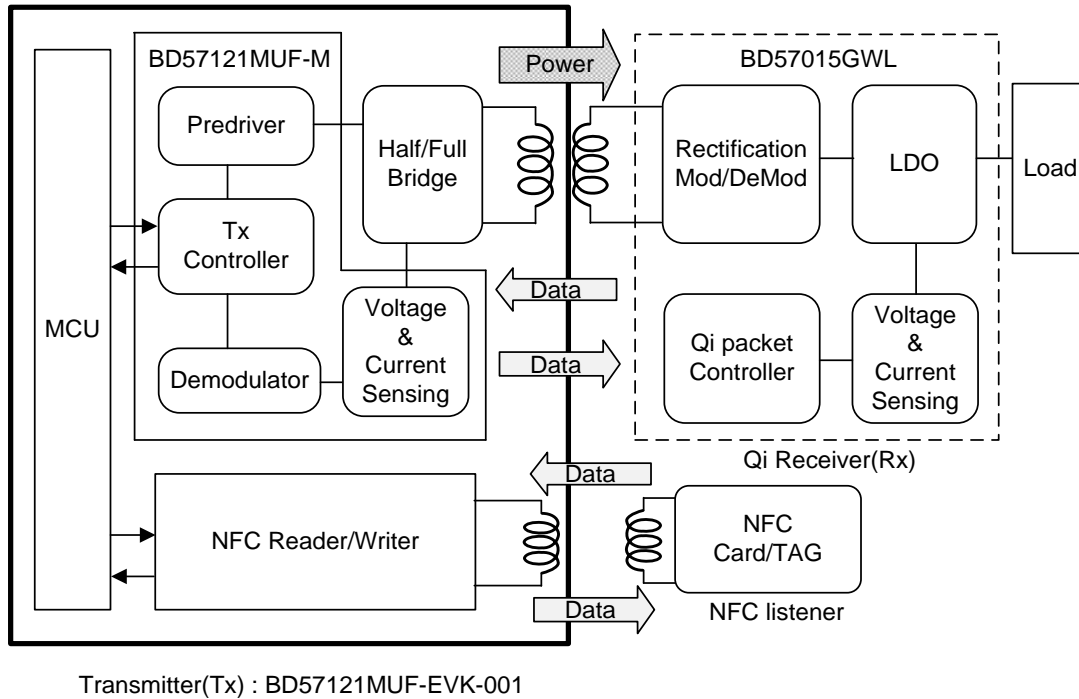

Figure 2. System configuration for wireless power transfer and NFC

2. Key components

The purpose of this EVK is to evaluate and verify key components needed for wireless power transfer and NFC detection. For more information, refer to the Web site for each product.

Manufacturer	Product	Part Number
ROHM Semiconductor	Wireless Power Transmitter IC	BD57121MUF-M
ROHM Semiconductor	Low Dropout Regulator IC	BD00C0AWFP-C
Infineon Technologies	Buck-Boost DC/DC controller IC	TLD5190QV
ST Microelectronics	NFC Reader/Writer IC	ST25R3914
ST Microelectronics	Microcontroller	STM8AF62A8
TDK	Qi Transmitter Coil	WT1005690-12F2-A6-G1
ROHM Semiconductor	NFC Antenna	- (PCB pattern)

3. Block diagram of the transmitter

BD57121MUF-M operates with a 5.4 V power supply. NFC reader IC ST25R3914 operates with a main power supply of 5.4 V and a sub of 3.3 V. The STM8AF MCU operates with a main power supply of 3.3 V. The peripheral voltage of the MCU is 3.3 V. The MCU communicates with the BD57121MUF-M via I²C bus, and with the ST25R3914 via SPI bus.

BD57121MUF-M functions as the analog front-end for wireless power transfer that is compliant to Qi ver 1.2.4, and it includes a D / A converter for voltage control, a pre-driver for driving the inverter bridge, an analog sensing circuit, and a selector circuit for multiple coils.

ST25R3914 is a high-sensitivity and high-power NFC / HF analog front-end that supports ISO14443A / B, ISO15693, FeliCa™ and ISO 18092 (NFCIP-1) active P2P. This IC directly drives the NFC antenna. Please contact ST Microelectronics regarding details of this IC.

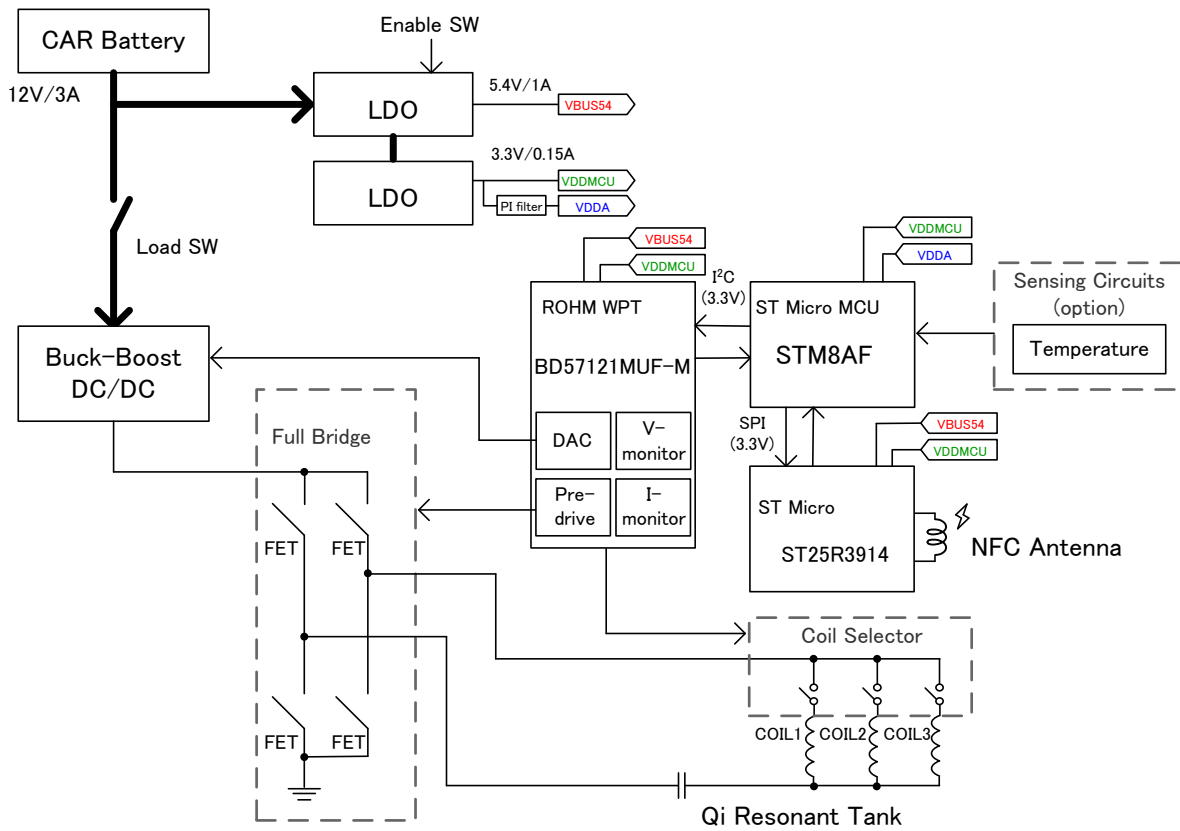

Figure 3. BD57121MUF-EVK-001 Block diagram

Operation Procedures

1. Required equipment

- (1) 12V, 3A DC power supply
- (2) BD57121MUF-EVK-001 Evaluation board (this EVK)
- (3) Qi compliant receivers (Qi compliant Smartphone / Rohm's EVK receiver: BD57015GWL-EVK-002)
- (4) Load (Electronic load or resistor is prepared as a load on the receiver side, if necessary)
- (5) DC voltage meter
- (6) NFC card / tag

2. Connecting the equipment

- (1) Set the DC power supply to 12V and turn off the power supply output.
- (2) Confirm that SW1 on the EVK is on the OFF side.
- (3) Connect the positive terminal of the power supply to the ADPV terminal and the negative terminal of the power supply to the GNDADPV terminal with a pair of wires.
- (4) Turn on the DC power supply output.
- (5) Set SW1 to ON, then LED4 lights on green.

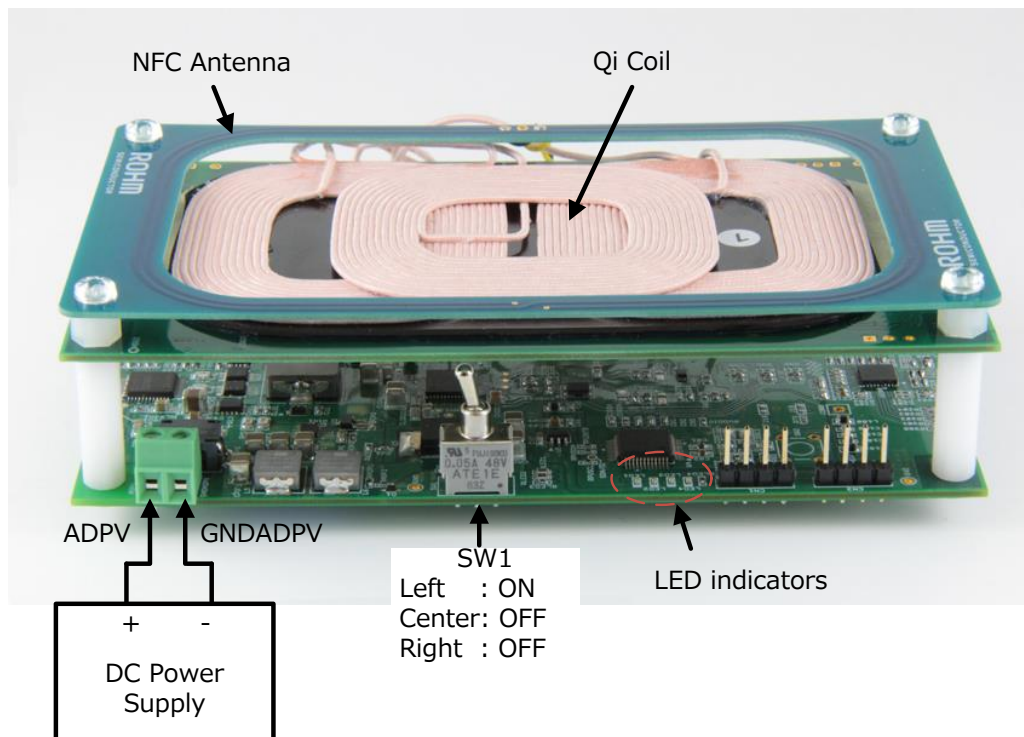

Figure 4. Connection

3. Operation of Wireless power transmission

- (1) Put Qi compliant receiver directly on top of the Qi coil of the transmitter.
- (2) When communication with the receiver is established, LED1 and LED2 light up in green according to the power profile of the receiver.
- (3) Connect the load.

4. Operation of NFC detection

- (1) Place the NFC card / tag near the NFC antenna (approx. at 5 cm distance).
- (2) LED3 lights on red during detection.

5. LED indicators

Tx Status	LED1(Green)	LED2(Green)	LED3(Red)	LED4(Green)
Disable (SW1=OFF)	OFF	OFF	OFF	OFF
Stand by(Idle)	OFF	OFF	OFF	ON
Qi BPP ^(*1) charging	ON	OFF	OFF	ON
Qi EPP ^(*2) charging	ON	ON	OFF	ON
During NFC detection ^(*3)	OFF	OFF	ON	ON
During Error detection ^(*4)	OFF	OFF	Blinking	ON

(*1) BPP (Baseline Power Profile): Capable wireless power supply up to 5W

(*2) EPP (Extended Power Profile): Capable wireless power supply up to 15W

(*3) LED3 also lights up when EVK protection circuit is activated.

Check whether there is abnormal heating on the board or overcurrent of the input power supply.

(*4) There are two types of error detection status.

- Foreign Object Detection

Make sure that no foreign objects are caught between the transmitter and receiver.

In addition, due to position gap of the coil, foreign object may be detected. Therefore, please align the center of the receiver coil with the center of Qi coil of the transmitter.

- End of Power Transfer

The transmitter has stopped transferring power because it has received a stop signal from the receiver that is in use.

Please check using another receiver if the same phenomenon occurs.

Circuit Diagram 1

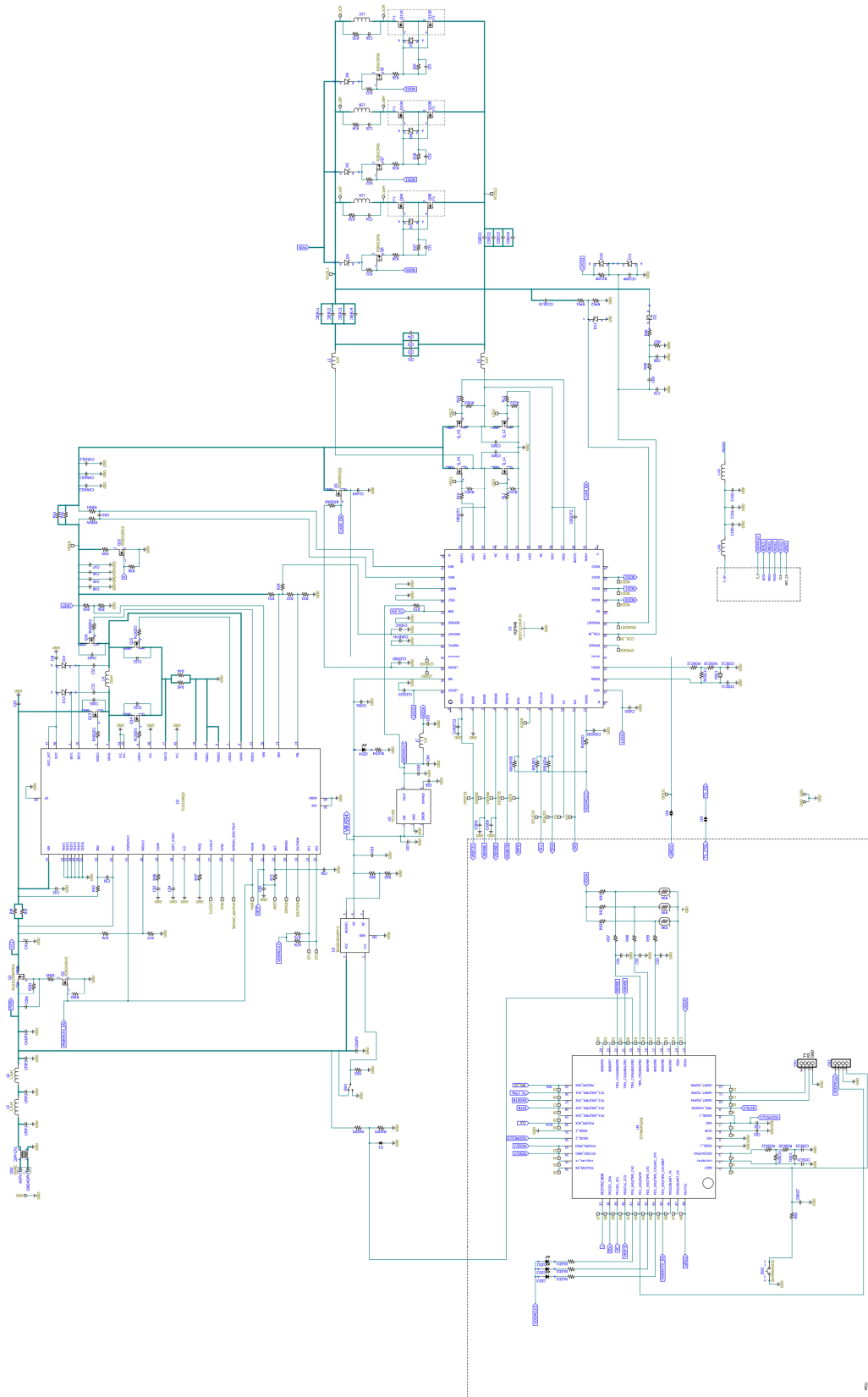

Figure 5. BD57121MUF-EVK-001 Circuit Diagram (1/2)

Circuit Diagram 2

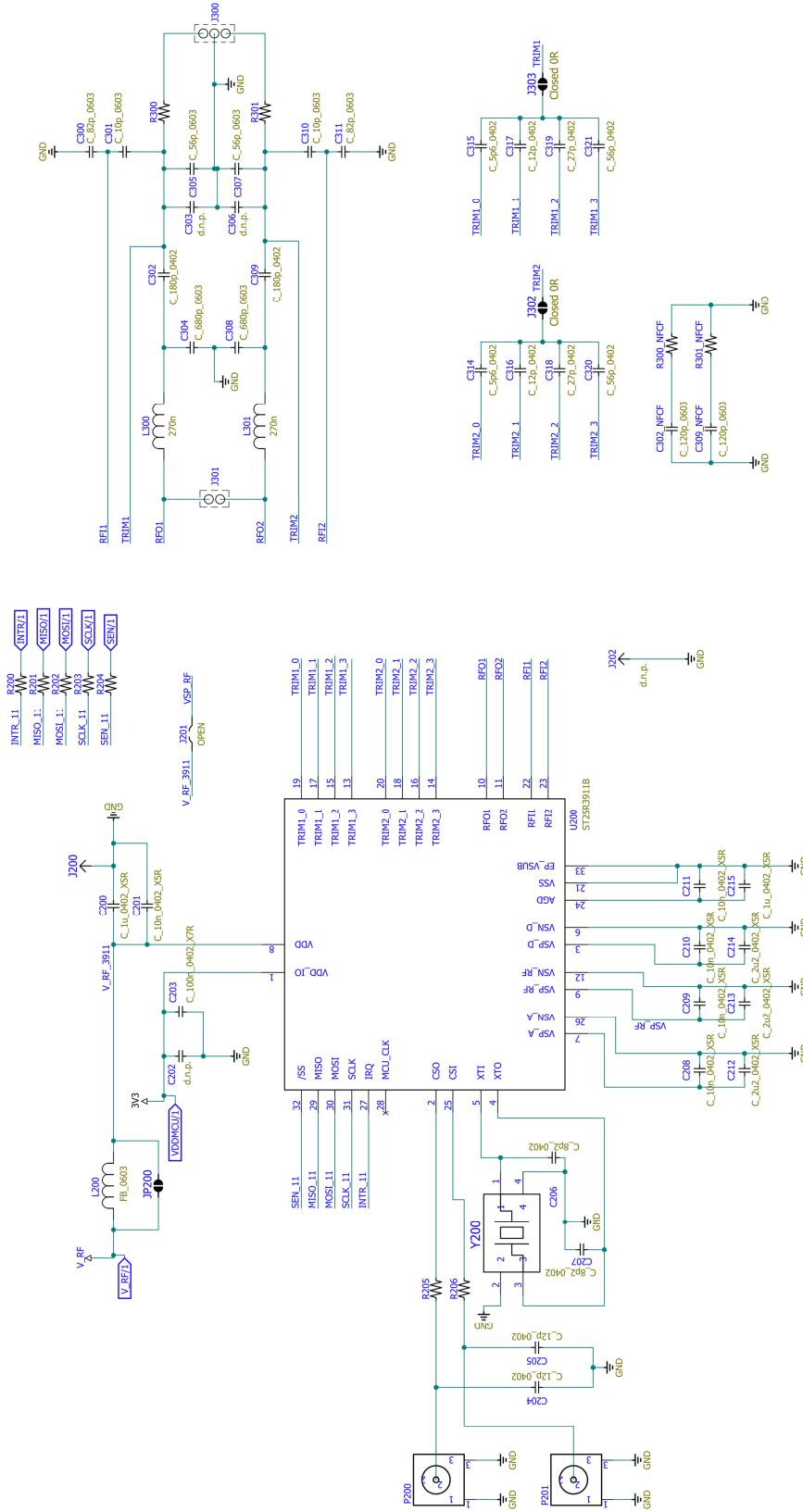

Figure 6. BD57121MUF-EVK-001 Circuit Diagram (2/2)

Bill of materials

Instance Name	Value	Description	Size	Part Number/Series	Manufacturer	Quantity
U1	-	IC, WIRELESS TRANSMITTER	48VQFN	BD57121MUF-M	ROHM	1
U2	-	IC,IC LED DRVR DCDC CTRLR	48VQFN	TLD5190VQ	INFINEON	1
U3	-	IC,IC REG LINEAR POS ADJ 1A	TO252-5	BD00C0AWFP-C	ROHM	1
U4	-	IC,IC MCU 8BIT 128KB FLASH	48LQFP	STM8AF62A8	STMICRO	1
U5	-	IC,IC REG LINEAR 3.3V 150MA	SOT23-5	TC1185-3.3VVCT713	MICROCHIP	1
U200	-	IC,NFC Initiator / HF Reader IC	QFN32	ST25R3914	STMICRO	1
Q_H1, Q_H2, Q_L1, Q_L2, Q5, Q13, Q14, Q15, Q16	-	MOSFET Nch 40V 30A	HSMT8	RQ3G150GNMHSTB	ROHM	9
Q1	-	MOSFET Pch 30V 7A	TSTM8	RQ1E070RPFRRATR	ROHM	1
Q2, Q12	-	MOSFET Nch 100V 1A	TSMT3	RSR010N10FHATL	ROHM	2
Q6, Q7, Q8	-	MOSFET Pch 60V 1.5A	TSMT3	RSR015P06FRATL	ROHM	3
Q9, Q10, Q11	-	MOSFET 2N-CH	8TDSO	IPG20N10S4L-35	INFINEON	3
D1	-	Diode,ZENER DIODES	EMD2	EDZVFHT2R36B	ROHM	1
D2, D4, D5, D6, D7, D8, D9, D13, D14	-	Diode,DIODE SCHOTTKY 100V	D_PMDU	RB578VYM100FHTR	ROHM	9
D10, D11, D12	-	Not mount	D_PMDU	-	-	-
LED1, LED2, LED4	-	LED, GREEN-YELLOW CLEAR	1006	SML-P11MTT86RG	ROHM	3
LED3	-	LED, RED CLEAR	1006	SML-P11VTT86RH	ROHM	1
L1	11.5 µH	Inductor, Qi Wireless 3 array coil	-	WT1005690-12F2-A6-G1	TDK	1
L2, L3	1 µH	Inductor 17.3A	-	ETQ-P4M1R0KVK	PANASONIC	2
L4	10 µH	Inductor, 7.6A	-	ETQ-P4M100KVC	PANASONIC	1
L5, L6	3.3 µH	Inductor, 6.1A	-	ETQ-P3M3R3KVN	PANASONIC	2
COM-CH1	700Ω	Inductor,CMC 5A 2LN	-	ACM90V-701-2PL-TL00	TDK	1
L7, L100, L101, L200	470Ω	Inductor, FERRITE BEAD	-	BLM18EG471SH1D	MURATA	4
L300, L301	180 nH	Inductor, 310mA, 1.65Ω	-	LQW18ANR18G8ZD	MURATA	2
RS1, RS2	0.1Ω	Resistor, Chip, 1/3W	1608	UCR10EVHFLR100	ROHM	2
RH1, RH2, RL1, RL2	10Ω	Resistor, Chip, 1/16W	1005	MCR01MZPD10R0	ROHM	4
RHD1, RHD2, RLD1, RLD2, RIN1, RIN2, R51, R65, R91, R92, R93	100 kΩ	Resistor, Chip, 1/16W	1005	MCR01MZPD1003	ROHM	11
RTX	-	Not mount	1005	-	-	-
RINVV, RINVI	22Ω	Resistor, Chip, 1/16W	1005	MCR01MZPD22R0	ROHM	2
RPK1	47 kΩ	Resistor, Chip, 1/10W	1608	MCR03EZPD4702	ROHM	1
RPK2	4.7 kΩ	Resistor, Chip, 1/10W	1608	MCR03EZPD4701	ROHM	1
RPUINTB, RPUSCL, RPUSDA	3.3 kΩ	Resistor, Chip, 1/16W	1005	MCR01MZPD3301	ROHM	3
RPUVAR, R21, R22, R23, RIN3, R74, R75	20 kΩ	Resistor, Chip, 1/16W	1005	MCR01MZPD2002	ROHM	7
R24, R25, R26	5.1 kΩ	Resistor, Chip, 1/16W	1005	MCR01MZPD5101	ROHM	3
R27, R28, R29, R55, R56	51 kΩ	Resistor, Chip, 1/16W	1005	MCR01MZPD5102	ROHM	5
R33, R34, R35	51Ω	Resistor, Chip, 1/10W	1608	MCR03EZPD51R0	ROHM	3
R41, R42	16 mΩ	Resistor, Chip, 1/3W	1608	UCR10PVHFXFSR016	ROHM	2
R43	51Ω	Resistor, Chip, 1/16W	1005	MCR01MZPD51R0	ROHM	1
R44, R45	20 mΩ	Resistor, Chip, 1/3W	1608	UCR10PVHFXFSR020	ROHM	2
R46	10 kΩ	Resistor, Chip, 1/16W	1005	MCR01MZPD1002	ROHM	1
R47	30 kΩ	Resistor, Chip, 1/16W	1005	MCR01MZPD3002	ROHM	1
RLSGD1, RLSGD2, RHSGD1, RHSGD2	0Ω	Resistor, Chip, 1/16W	1005	MCR01MZPJ000	ROHM	4
R52, R68, R97, R98, R99, RLED3, RLED4	1 kΩ	Resistor, Chip, 1/16W	1005	MCR01MZPD1001	ROHM	7
R53	3 kΩ	Resistor, Chip, 1/16W	1005	MCR01MZPD3001	ROHM	1
R54	24 kΩ	Resistor, Chip, 1/16W	1005	MCR01MZPD2402	ROHM	1
R58, RCLMP	100 kΩ	Resistor, Chip, 1/10W	1608	MCR03EZPD1003	ROHM	2
R59	510Ω	Resistor, Chip, 1/10W	1608	MCR03EZPD5100	ROHM	1
R61	62 kΩ	Resistor, Chip, 1/16W	1005	MCR01MZPD6202	ROHM	1
R62	10 kΩ	Resistor, Chip, 1/16W	1005	MCR01MZPD1002	ROHM	1
R66	2.4 kΩ	Resistor, Chip, 1/10W	1608	MCR03EZPD2401	ROHM	1
R67	330 kΩ	Resistor, Chip, 1/10W	1608	MCR01MZPD3303	ROHM	1
R68	22 kΩ	Resistor, Chip, 1/16W	1005	MCR01MZPD2202	ROHM	1
R71	100Ω	Resistor, Chip, 1/10W	1005	MCR01MZPD1000	ROHM	1
R76	47 kΩ	Resistor, Chip, 1/16W	1005	MCR01MZPD4702	ROHM	1
R77	6.8 kΩ	Resistor, Chip, 1/16W	1005	MCR01MZPD6801	ROHM	1
R82	10 kΩ	Resistor, Chip, 1/10W	1608	MCR03EZPD1002	ROHM	1
ROSC11	1 MΩ	Resistor, Chip, 1/16W	1005	MCR01MZPD1004	ROHM	1
ROSC12	15Ω	Resistor, Chip, 1/16W	1005	MCR01MZPD15R0	ROHM	1
ROSC21	10 MΩ	Resistor, Chip, 1/10W	1608	MCR03EZPF1005	ROHM	1
ROSC22	15Ω	Resistor, Chip, 1/10W	1608	MCR03EZPD15R0	ROHM	1
RLED1, RLED2	680Ω	Resistor, Chip, 1/16W	1608	MCR03EZPD6800	ROHM	2
RADP1	120 kΩ	Resistor, Chip, 1/16W	1005	MCR01MZPD1203	ROHM	1
RADP2	18 kΩ	Resistor, Chip, 1/16W	1005	MCR01MZPD1802	ROHM	1
R200, R201, R202, R203, R204	220Ω	Resistor, Chip, 1/16W	1005	MCR01MZPD2200	ROHM	5
R205, R206	1 kΩ	Resistor, Chip, 1/16W	1005	MCR01MZPD1001	ROHM	2
R300_NFCF, R301_NFCF	2Ω	Resistor, Chip, 1/10W	1608	MCR03EZPD2R00	ROHM	2
R300, R301	1 Ω	Resistor, Chip, 1/10W	1608	MCR03EZPD1R00	ROHM	2

Instance Name	Value	Description	Size	Part Number/Series	Manufacturer	Quantity
CPIF1, CVRAIL1, C42, C45, C48	20 μ F	Capacitor, Chip, 25V	3126	GCM32EC71E226KE36L	MURATA	5
CPIF2, CPIF3, CADP1, CADP2, CVIN, C61	10 μ F	Capacitor, Chip, 35V	3126	GCM32EC7YA106KA03L	MURATA	6
CIN1, C43, C46, C55, C63, C67	1.0 μ F	Capacitor, Chip, 25V	1608	GCM188R71E105KA64D	MURATA	6
CLVAR, CLDO50, CLDO33	4.7 μ F	Capacitor, Chip, 25V	2012	GCM21BC71E475KE36L	MURATA	3
CBOOT1, CBOOT2, C47, C51, C52, C56, C64, C65, C91, C92, C93, CNRST	0.1 μ F	Capacitor, Chip, 50V	1005	GRT155R71E104KE01#	MURATA	12
CCOILV2, C24, C25, C26	1000 pF	Capacitor, Chip, 250V	2012	GCM21A5C2E102JX01#	MURATA	4
CVREF33, CVREF41, CRS, C44, C50	2.2 μ F	Capacitor, Chip, 25V	2012	GCM21BR71E225KA73L	MURATA	5
CVDDIO, CVDD	1.0 μ F	Capacitor, Chip, 25V	1608	GCM188R71E105KA64D	MURATA	2
CVRAIL2, CVRAIL3, CISEN	0.1 μ F	Capacitor, Chip, 50V	1005	GRT155R71E104KE01#	MURATA	3
CSER11, CSER12, CP1, CP2, CP3, CP4	0.1 μ F	Capacitor, Chip, 450V	3216	GC332DD72W104KX01L	MURATA	6
CSR13, CSR14	-	Not mount	3216	-	-	-
CVDAC, C21, C22, C23, C202	-	Not mount	1005	-	-	-
CSW1, CSW2	-	Not mount	1608	-	-	-
C53, C54	0.022 μ F	Capacitor, Chip, 50V	1005	GRT155R71H223KE01D	MURATA	2
CLS1, CLS2, CHS1, CHS2	100 pF	Capacitor, Chip, 50V	1005	GRT1555C1H101JA02#	MURATA	4
C66	470 pF	Capacitor, Chip, 50V	1005	GRT1555C1H471JA02#	MURATA	1
C68	2200 pF	Capacitor, Chip, 50V	1608	GRT1885C1H222JA02#	MURATA	1
C69	0.022 μ F	Capacitor, Chip, 50V	1005	GRT155R71H223KE01D	MURATA	1
C70	680 pF	Capacitor, Chip, 50V	1005	GRT1555C1H681JA02#	MURATA	1
C81, C82	0.47 μ F	Capacitor, Chip, 10V	1005	GRT155R71A474ME01#	MURATA	2
COSC11, COSC12	10 pF	Capacitor, Chip, 100V	1005	GRT1555C2A100JA02D	MURATA	2
COSC21, COSC22	3.3 pF	Capacitor, Chip, 100V	1005	GRT1555C2A3R3CA02D	MURATA	2
C100	100 pF	Capacitor, Chip, 50V	1005	GRT1555C1H101JA02#	MURATA	1
C101, C208, C209, C210, C211	0.01 μ F	Capacitor, Chip, 25V	1005	GRT155R71E103KE01#	MURATA	5
C102, C212, C213, C214	2.2 μ F	Capacitor, Chip, 10V	1005	GRT155C71A225KE13D	MURATA	4
C200, C215	1.0 μ F	Capacitor, Chip, 25V	1608	GCM188R71E105KA64D	MURATA	2
C201, C203	0.1 μ F	Capacitor, Chip, 50V	1005	GRT155R71E104KE01#	MURATA	2
C204, C205, C316, C317	12 pF	Capacitor, Chip, 50V	1005	GRT1555C1H120JA02#	MURATA	4
C206, C207	8.2 pF	Capacitor, Chip, 50V	1005	GCM1555C1H8R2DA16D	MURATA	2
C300, C311	150 pF	Capacitor, Chip, 50V	1608	GRT1885C1H151JA02#	MURATA	2
C301, C310	10 pF	Capacitor, Chip, 100V	1005	GRT1555C2A100JA02#	MURATA	2
C302, C309	220 pF	Capacitor, Chip, 50V	1005	GRT1555C1H221JA02#	MURATA	2
C302_NFCF, C309_NFCF	120 pF	Capacitor, Chip, 50V	1005	GRT1555C1H121JA02#	MURATA	2
C304, C308	1200 pF	Capacitor, Chip, 50V	1608	GRT1885C1H122JA02#	MURATA	2
C303, C306	39 pF	Capacitor, Chip, 50V	1608	GRT1885C1H390JA02#	MURATA	2
C305, C307	39 pF	Capacitor, Chip, 50V	1608	GRT1885C1H390JA02#	MURATA	2
C314, C315	5.6 pF	Capacitor, Chip, 50V	1005	GCM1555C1H5R6BA16D	MURATA	2
C318, C319	27 pF	Capacitor, Chip, 50V	1005	GRT1555C1H270JA02#	MURATA	2
C320, C321	56 pF	Capacitor, Chip, 50V	1005	GRT1555C1H560JA02#	MURATA	2
OSC1	48 MHz	Oscillator, CRYSTAL, 8PF	3225	NX3225GA EXS00A-CG07369	NDK	1
OSC2	-	Not mount	3225	-	-	1
Y100	27.12 MHz	Oscillator, CRYSTAL, 6PF	2016	XRCGB27M120F3A00R0	MURATA	1
RVDDIO, ROSC10, ROSC20, CSER21, CSER22, CSER23, CSER24	-	Jumper, SOLDER SHORT JUMPER	-	-	-	-
J302, J303	0 Ω	Resistor, Chip, 1/16W	1005	MCR01MZPJ000	ROHM	2

Layout 1

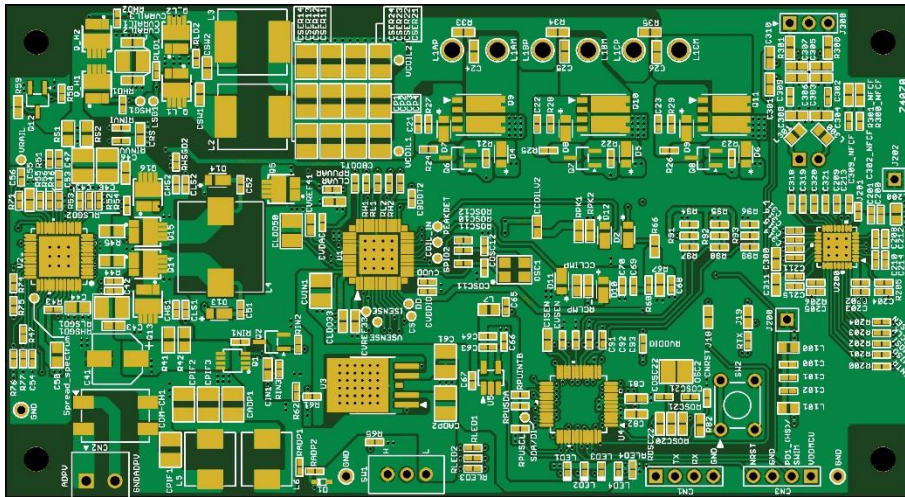

Figure 7. Top silk screen, layout (Top View)

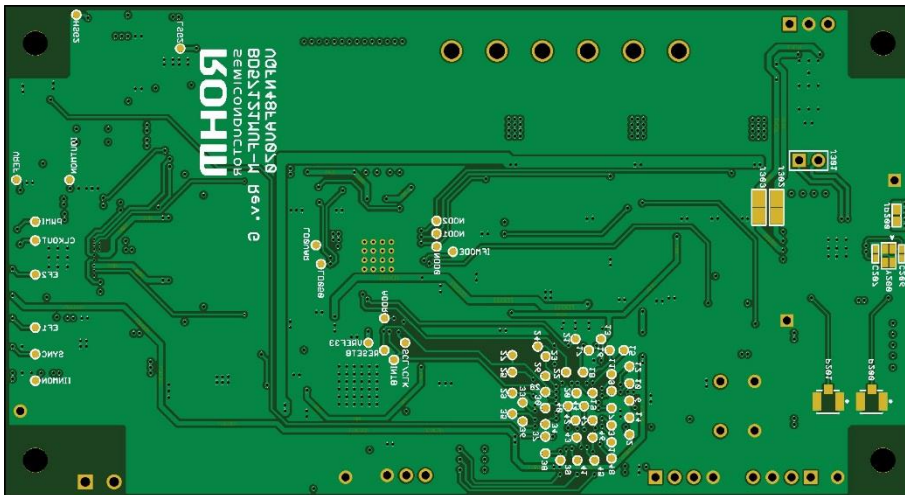

Figure 8. Bottom silk screen, layout (Top View)

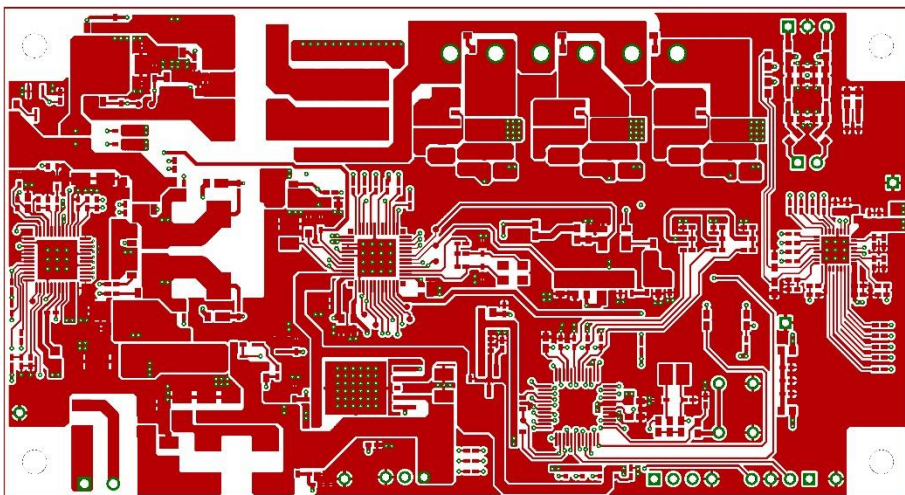

Figure 9. TOP Layer layout (Top View)

Layout 2

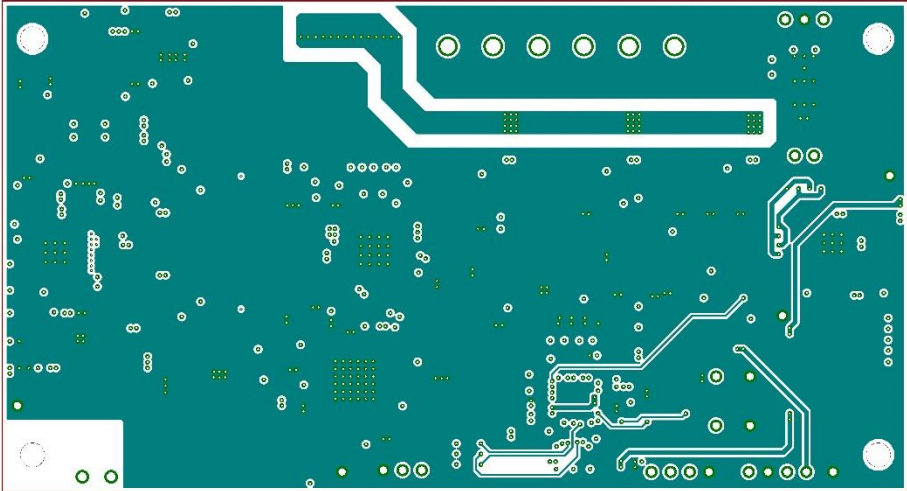

Figure 10. Middle Layer 1 layout (Top View)

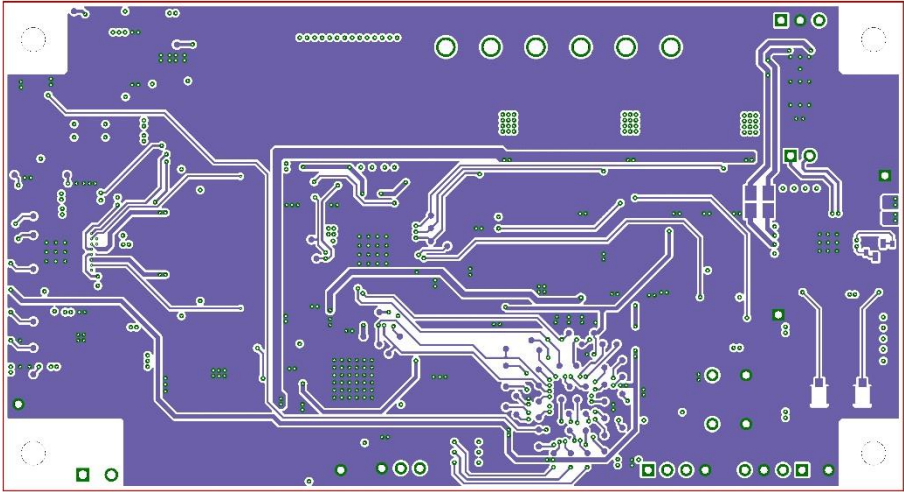

Figure 11. Middle Layer 2 layout (Top View)

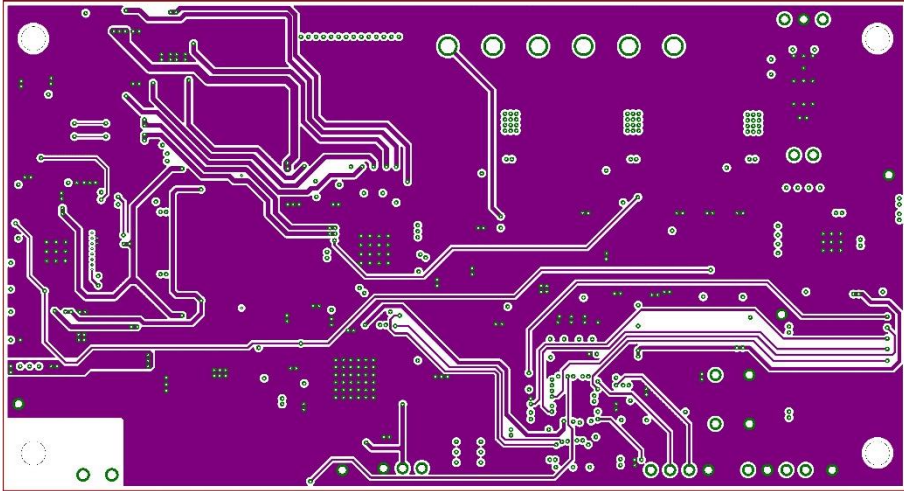

Figure 12. Bottom Layer layout (Top View)

Reference Application data

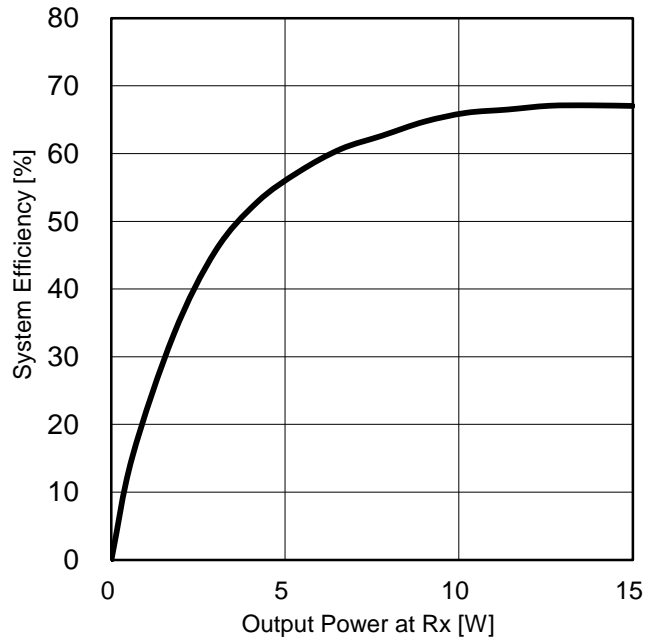

Figure 13. System Efficiency vs POUT (EPP)

Rx: BD57015GWL-EVK-002(ROHM), 12V output

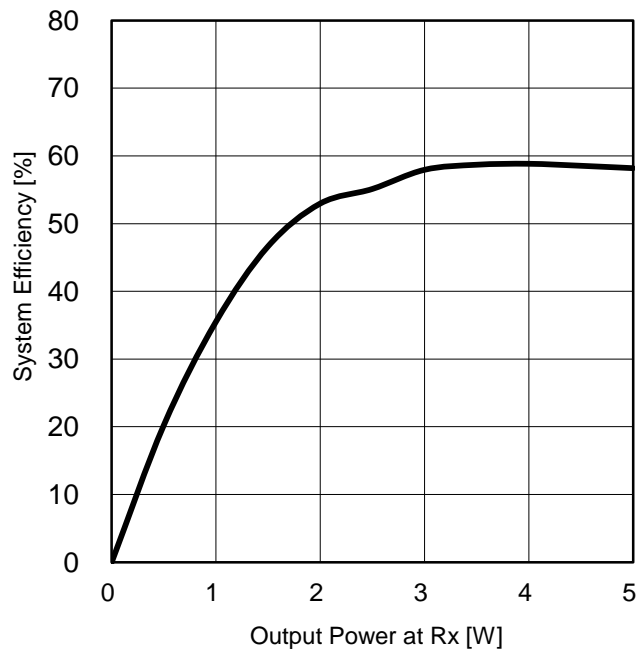

Figure 14. System Efficiency vs POUT (BPP)

Rx: BD57011AGWL (ROHM), 5V output

Revision history

date	Revision	Changes
16. Jan. 2019	001	New release

Notes

- 1) The information contained herein is subject to change without notice.
- 2) Before you use our Products, please contact our sales representative and verify the latest specifications :
- 3) Although ROHM is continuously working to improve product reliability and quality, semiconductors can break down and malfunction due to various factors.
Therefore, in order to prevent personal injury or fire arising from failure, please take safety measures such as complying with the derating characteristics, implementing redundant and fire prevention designs, and utilizing backups and fail-safe procedures. ROHM shall have no responsibility for any damages arising out of the use of our Products beyond the rating specified by ROHM.
- 4) Examples of application circuits, circuit constants and any other information contained herein are provided only to illustrate the standard usage and operations of the Products. The peripheral conditions must be taken into account when designing circuits for mass production.
- 5) The technical information specified herein is intended only to show the typical functions of and examples of application circuits for the Products. ROHM does not grant you, explicitly or implicitly, any license to use or exercise intellectual property or other rights held by ROHM or any other parties. ROHM shall have no responsibility whatsoever for any dispute arising out of the use of such technical information.
- 6) The Products specified in this document are not designed to be radiation tolerant.
- 7) For use of our Products in applications requiring a high degree of reliability (as exemplified below), please contact and consult with a ROHM representative : transportation equipment (i.e. cars, ships, trains), primary communication equipment, traffic lights, fire/crime prevention, safety equipment, medical systems, servers, solar cells, and power transmission systems.
- 8) Do not use our Products in applications requiring extremely high reliability, such as aerospace equipment, nuclear power control systems, and submarine repeaters.
- 9) ROHM shall have no responsibility for any damages or injury arising from non-compliance with the recommended usage conditions and specifications contained herein.
- 10) ROHM has used reasonable care to ensure the accuracy of the information contained in this document. However, ROHM does not warrants that such information is error-free, and ROHM shall have no responsibility for any damages arising from any inaccuracy or misprint of such information.
- 11) Please use the Products in accordance with any applicable environmental laws and regulations, such as the RoHS Directive. For more details, including RoHS compatibility, please contact a ROHM sales office. ROHM shall have no responsibility for any damages or losses resulting non-compliance with any applicable laws or regulations.
- 12) When providing our Products and technologies contained in this document to other countries, you must abide by the procedures and provisions stipulated in all applicable export laws and regulations, including without limitation the US Export Administration Regulations and the Foreign Exchange and Foreign Trade Act.
- 13) This document, in part or in whole, may not be reprinted or reproduced without prior consent of ROHM.



Thank you for your accessing to ROHM product informations.
More detail product informations and catalogs are available, please contact us.

ROHM Customer Support System

<http://www.rohm.com/contact/>